

- Alloy steel IP67 shear beam load cell
- Adhesive sealed
- Suitable for platform weighing, bed weighing, etcetera
- High accuracy, high reliability

Capacity	Accuracy	Part-Number
500 kg	C3	H8C-C3-500kg-4B ³
xx t	C3	H8C-C3-xxt-xB ¹³

Specification:

Accuracy class		OIML R60 C3		
Output sensitivity (= FS)	mV/V	3.0 ± 0.003		
Maximum capacity (E _{max})	kg	0.5, 1, 1.5, 2, 2.5, 3, 5, 10 ¹		
Maximum number of load cell intervals (n _{LC})		3000		
Ratio of minimum LC verification interval Y = E _{max} / V _{min}		0.5 - 2.5t: 10000 or 15000 ²	3 and 5t: 7000	10t: 4000
Combined Error	%FS	± 0.020		
Minimum dead load	kg / klb	0		
Safe overload	of E _{max}	150 %		
Ultimate overload	of E _{max}	300 %		
Zero balance	of FS	< ± 1.0 %		
Excitation, recommended voltage	V	5 ~ 12		
Excitation maximum	V	18		
Terminal resistance, input	Ω	350 ± 3.5		
Terminal resistance, output	Ω	351 ± 2		
Insulation impedance	MΩ	≥ 5000 (at 50VDC)		
Temperature range, compensated	°C	-10 ~ +40		
Temperature range, operating	°C	-35 ~ +65		
Element material		Alloy steel		
Ingress Protection (according to EN 60529)		IP67		
Recommended torque on fixation bolts	Nm	M12: 100	M18: 200	M24: 700
ATEX classification (optional)		II1G Ex ia II1C T4	II1D Ex iaD 20 T73°C	II3G nL II C T4

Note 1: Imperial versions available Note 2: Y value is indicated on the load cell Note 3: Current calibration (SC) is optional

Outline Dimensions in mm

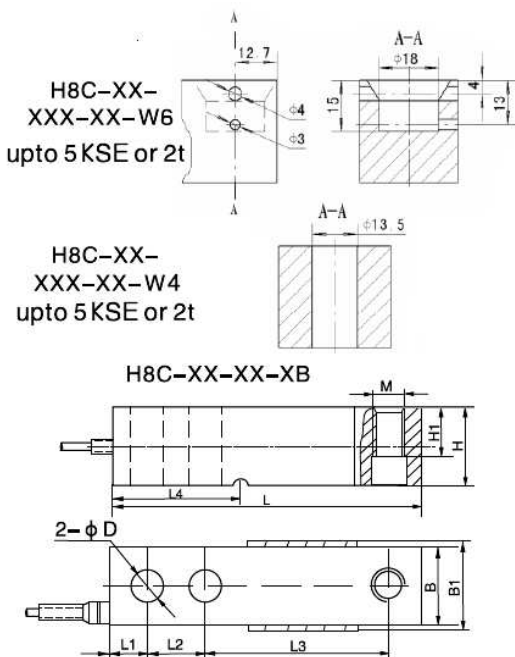

Dimension / Capacity	L	L1	L2	L3	L4	H	H1	B	B1	φ D	M	
500kg-2000kg	130 (5.12)	15.8 (0.62)	25.4 (1.0)	76.2 (3.0)	54.2 (2.13)	31.8 (1.25)	15.8 (0.62)	31.8 (1.25)	34 (1.34)	13.5 (0.53)	M12 × 1.75	
1-4klb	130 (5.12)	15.8 (0.62)	25.4 (1.0)	76.2 (3)	54.2 (2.13)	31.8 (1.5)	15.8 (0.62)	31.8 (1.25)	34 (1.34)	13.5 (0.53)	1/2-20UNF	
5klb (SE)	130 (5.12)	15.8 (0.62)	25.4 (1.0)	76.2 (3)	54.2 (2.13)	38.1 (1.5)	15.8 (0.62)	31.8 (1.25)	34 (1.34)	13.5 (0.53)	1/2-20UNF	
2500kg-5000kg	171.5 (6.75)	19.1 (0.75)	38.1 (1.5)	95.3 (3.75)	77.2 (3.04)	38.1 (1.5)	18.8 (0.74)	38.1 (1.5)	40 (1.57)	19.8 (0.78)	M18 × 1.5	
5-10klb	171.5 (6.75)	19.1 (0.75)	38.1 (1.5)	95.3 (3.75)	77.2 (3.04)	38.1 (1.5)	18.8 (0.74)	38.1 (1.5)	40 (1.57)	19.8 (0.78)	3/4-16UNF	
10t	222.3 (8.75)	25.4 (1.0)	50.8 (2.0)	120.7 (4.75)	101.6 (4)	50.8 (2.0)	52.4 (1)	50.8 (2)	52.4 (2.06)	26 (1.02)	26.92 (1.06)	M24 × 2
20klb	222.3 (8.75)	25.4 (1.0)	50.8 (2.0)	120.7 (4.75)	101.6 (4)	50.8 (2.0)	52.4 (1)	50.8 (2)	52.4 (2.06)	26 (1.02)	26.92 (1.06)	1-12UNF

Wiring:

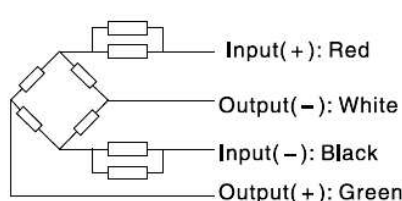

- Shielded, 4 conductor cable: Φ5 mm.
- Standard cable length: 4m(0.5t~2t), 6m(2.5t~10t)(1klb~20klb).
- Cable type and cable length for customer's own application are available on request.
- Shield not connected to element.