

MNC SERIES



Miniature - Load Cell
50kg / 100kg / 200kg / 500kg
1t / 2t / 5t / 10t / 20t



- Stainless steel
- Compression application



Technical Specifications

		50kg, 100kg, 200kg, 500kg, 1t, 2t, 5t, 10t, 20t
Max Capacity (rated load)	kgf	
Rated Output	mV / V	2.0 ± 0.005
Zero Balance	mV / V	0.0 ± 0.06
Accuracy Class	-	-
Combined Error	% R.O.	0.15
Repeatability	% R.O.	0.05
Creep for 30min.	% R.O.	0.03
Resolution	-	≤1/600
Division	mV/V	0.003
Temperature Effect on - Zero Value	%/10 °C	0.05
Temperature Effect on - Output Value	%/10 °C	0.1
Excitation - Recommended	V	10
Excitation - Maximum	V	15
Resistance - Input	Ω	420 ± 30
Resistance - Output	Ω	350 ± 3.5
Resistance - Insulation	MΩ	> 2000
Compensated Temperature Range	°C	-10 to +40
Operating Temperature Range	°C	-20 to +80
Safety Overload	% R.L	150%
Cable Specification	-	ø5.4 x 4p x 3M(5)M

Dimension

Unit in mm

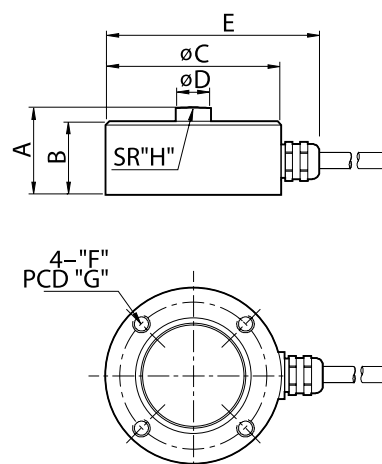

Capacity	A	B	C	D	E	F	G	H	Cable (m)
50kg									
100kg									
200kg	25	11	50	10	66	M5 X 0.8dp7	42	50	3
500kg									
1t									
2t									
5t	40	35	98	20	113.5	M6 X 1.0dp8	72	150	
10t	45	40	98	20	115	M6 X 1.0dp8	72	150	5
20t	50	45	118	20	133.5	M8 X 1.25dp10	90	250	



UNIT 8, NORTHLINK, 459 TUFNELL ROAD
 BANYO QLD 4014, AUSTRALIA

TEL: +61 (0)7 3267 7767 FAX: +61 (0)7 32 67 1818

EMAIL: sales@cassscale.com.au

<http://www.cassscale.com.au>

Specifications are subject to change for improvement without prior notice.

